

Atacama



Multi-Media Furniture Specialist

Hi Fi & AV Furniture

WHAT HI-FI?
SOUND AND VISION



ELITE ECO 24
AUGUST 2023



WHAT HI-FI?
★★★★
AWARDS 2020

BEST EQUIPMENT RACK
Atacama Evoque 60-40 SE2

WHAT HI-FI?
★★★★
AWARDS 2021

BEST EQUIPMENT RACK
Atacama Evoque Eco
60-40 SE2

WHAT HI-FI?
★★★★
AWARDS 2022

BEST EQUIPMENT RACK
Atacama Evoque
Eco 60-40 SE2

WHAT HI-FI?
★★★★
AWARDS 2023

BEST EQUIPMENT
RACK
ATACAMA EVOQUE
ECO 60-40 SE2

WHAT HI-FI?
★★★★
AWARDS 2016

Accessories
Best equipment rack
Atacama Evoque Eco 60-40 SE

WHAT HI-FI?
★★★★
AWARDS 2017

Accessories
Best equipment rack
Atacama Evoque Eco 60-40 SE

WHAT HI-FI?
★★★★
AWARDS 2018

Accessories
Best equipment rack
Atacama Evoque Eco 60-40 SE

WHAT HI-FI?
★★★★
AWARDS 2019

Accessories
Best equipment rack
Atacama Evoque Eco 60-40 SE2

WHAT HI-FI?
SOUND AND VISION
AWARDS 2012

CABLES & ACCESSORIES
BEST EQUIPMENT SUPPORT
ATACAMA ERIS ECO 5.0

WHAT HI-FI?
SOUND AND VISION
WHATHIFI.COM
AWARDS 2013

ACCESSORIES
BEST EQUIPMENT SUPPORT
ATACAMA ERIS ECO 5.0

WHAT HI-FI?
AWARDS 2014

Accessories
Best equipment support
Atacama Evoque Eco 60-40

WHAT HI-FI?
AWARDS 2015

Accessories
Best equipment rack
Atacama Evoque Eco 60-40
Special Edition



Featuring The ((apollo)) Oak Support Range

Setting the standard since 1975

Introduction

For over 30 years, Atacama and Apollo HiFi and AV supports have been designed and made in the UK by our dedicated team of craftsmen.

Winning numerous awards and accolades, Atacama furniture is aesthetically pleasing, functional, practical and adaptable, with the latest range of Evoque bamboo based supports bringing innovative new technologies to hifi furniture design.

Apollo Oak supports share many features with the Bamboo designs, but being a more traditional furniture material allows our designers to expand the lifestyle aspect of the racks. This includes practical solutions to specific requirements like vinyl storage or, in the case of Storm 10AV, cable management.

As primary materials, Atacama's high density Bamboo and Apollo's solid Oak were chosen because of their suitability when interfacing with the supported HiFi and AV equipment. As natural materials, part of the intrinsic beauty of these woods means each module is aesthetically unique, making your chosen rack one of a kind.

The Bamboo and Oak we use are natural materials, so colour variations will be present. Do not attempt to colour match using the photography shown in this brochure. For further details about finishes, please be sure to read the "Bamboo & Oak Colour Information" section on the back page.

Contents

Apollo HiFi & AV supports

- Page 3 Apollo Storm 6 HiFi rack
- Page 4 Apollo Storm 6 Vinyl Storage module
- Page 5 Apollo Storm 10 HiFi/ AV rack
- Page 6 Apollo Storm 10AV 2 shelf AV rack

Eris series:-

- page 7 Atacama Eris2 Eco 5.0 Hi-fi Support

Evoque Eco Series:-

- Page 8 Atacama Evoque Eco 35-40 Compact
- Page 9 Atacama Evoque Eco 60-40 HiFi rack
- Page 10 Atacama Evoque Eco 110-40 HiFi/AV rack
- Page 11 Atacama Evoque Eco 60-40 Special Edition HiFi Rack
- Page 12 Atacama Evoque Eco 60-40 SE2 HiFi rack
- Page 13 Atacama Evoque Design Editions Hifi & AV racks
- Page 14 Atacama Evoque Eco 65-60 SE2
- Page 15 Atacama Evoque Eco 65-60 SE2 Reference Detailed Cutout
- Page 16 Atacama Elite Eco 24 HiFi rack (Natural Bamboo Finish)
- Page 17 Atacama Elite Eco 24 HiFi rack (Dark Bamboo Finish)
- Page 18 Atacama Elite Eco 24 Vinyl Storage Module (Natural Bamboo Finish)
- Page 19 Atacama Elite Eco 24 Vinyl Storage Module (Dark Bamboo Finish)
- Page 20 Atacama 60-65 Monoplinth support
- Page 21 Atacama Universal Cable Management Rack Accessory
- Pages 22-35 Technical Dimensions
- Page 36 Leg Height/ and wood colour information

Accessories:-

Most Apollo and Atacama racks have spiked feet. It is strongly recommended to use Atacama HD-L spike shoes if your rack is to be placed on a delicate floor covering.



Apollo Storm 6 Solid Oak Modular HiFi Rack

- Stable, adjustable 4 leg design.
- Solid 26mm thick Oak shelves.
- Two choices of Oak finishes available.
- Each module is isolated via four 8mm steel spikes.
- Modular design, with 4 choices of shelving height.

WHAT HI-FI?
SOUND AND VISION



2018



Silk Black/ Natural Oak Finish



Stackable Modular Design



Dark Oak Finish



Natural Oak Finish



Silk Black/ Dark Oak Finish



Silk Black/ Natural Oak Finish

Apollo Storm 6 Solid Oak Vinyl Storage Module

- Stable, 4 leg design with adjustable isolation spikes as standard.
- Two Solid 26mm thick Oak shelves.
- Two choices of Oak finishes available.
- Standard Storm 6 modules can be added.
- Stores up to 150 12" LP's.
- Silk Black or Glazier White leg colour options.



Silk Black/ Natural Oak Finish



Stackable Modular Design



Silk Black/ Dark Oak Finish



Dark Oak Finish



Natural Oak Finish



Two Apollo Storm 6 shelves, one Vinyl Storage module and matching Cyclone speaker stands

Apollo Storm 10 Solid Oak Modular Rack

- Suitable for both HiFi and AV applications.
- Solid 26mm thick Oak shelves.
- Two choices of Oak finishes available.
- Each module is isolated via four 8mm steel spikes.
- Modular design, with 4 choices of shelving height.

Silk Black/ Natural Oak Finish



Glazier White/
Natural Oak Finish



Dark Oak Finish



Natural Oak Finish

Stackable Modular Design
Silk Black/ Dark Oak Finish



Silk Black/ Natural Oak Finish



Apollo Storm 10AV Solid Oak Rack

- Cable management panel included.
- Two solid 26mm thick Oak shelves.
- Two choices of Oak finishes available.
- Standard Storm 10 modules can be added if more storage is required.
- Glider feet included.
- Silk Black or Glazier White leg colour options.
- Extra high 335mm storage space.



Silk Black/ Natural Oak Finish



Glide Feet



Dark Oak Finish



Natural Oak Finish



Silk Black/
Natural Oak Finish



Stackable Modular Design

Atacama

ERIS2 ECO 5.0 HiFi Rack

- Stable, adjustable 3 leg design.
- Solid 40mm thick carbonised Bamboo shelving.
- Two choices of Bamboo finish available.
- A choice of Satin Black or Diamond White frame colours.
- Each module is isolated via three 8mm steel spikes.
- Modular design, with 3 choices of shelving height.



Stackable Modular Design

Satin Black/ Natural Bamboo Finish



Natural Bamboo



Dark Bamboo

- See Bamboo Colour Information



Diamond White/ Natural
Bamboo Finish



Satin Black/ Dark Bamboo
Finish

Atacama

EVOQUE ECO 35-40 COMPACT HiFi Rack

- Designed to support compact hifi components.
- Solid 40mm thick carbonised Bamboo shelving.
- Modules feature mechanical grounding designed to direct resonance away from the supported equipment.
- Each module is isolated via four adjustable 8mm BZP spikes.
- Modular design, with 4 choices of extra shelving height.
- Each leg is supplied with a Shelf to leg Isolation disc.
- Twin dampening ASIST gaskets incorporated into each leg.
- Adaptable design; multiple configurations can be achieved utilising the various leg height options available.



Modular Design

Gloss Black/ Natural
Bamboo Finish



Natural Bamboo



Dark Bamboo

- See Bamboo Colour Information

Atacama

EVOQUE ECO 60-40 HiFi Rack

- Designed to support most standard sized hi fi components.
- Solid 40mm thick carbonised Bamboo shelving.
- Modules feature mechanical grounding designed to direct resonance away from the supported equipment.
- Each module is isolated via four adjustable 8mm BZP spikes.
- Modular design, with 4 choices of extra shelving height.
- Each leg is equipped with a Shelf-to-leg Isolation disc.
- Twin dampening ASIST gaskets incorporated into each leg.
- Adaptable design; multiple configurations can be achieved utilising the various leg height options available.



Modular
Design

Gloss Black/ Dark Bamboo Finish

WHAT HI-FI?
AWARDS 2014

Accessories
Best equipment support
Atacama Evoque Eco 60-40



Natural Bamboo



Dark Bamboo

- See Bamboo Colour Information

Atacama

EVOQUE ECO 110-40 HiFi & AV Rack

- Designed to support most standard sized AV components.
- Solid 40mm thick carbonised bamboo shelving.
- Modules feature mechanical grounding designed to direct resonance away from the supported equipment.
- Each module is isolated via four adjustable 8mm BZP spikes.
- Modular design, with 4 choices of extra shelving height.
- Easy assembly, no tools required.
- Twin dampening ASIST gaskets incorporated into each leg.
- Adaptable design; multiple configurations can be achieved utilising the various leg height options available.
- Based on the award winning Atacama Evoque Eco 60-40 HiFi rack.



Gloss Black/
Natural Bamboo
Finish



Modular
Design



Natural Bamboo



Dark Bamboo

- See Bamboo Colour Information

Atacama

EVOQUE ECO 60-40 SPECIAL EDITION HiFi Rack

- Features as Evoque Eco 60-40 with the following upgrades/additions:-



- 15mm longer legs than standard Evoque leg options.
- Frostrum adjustable leg tuning weights fitted inside each leg.
- Upgraded spike component that is designed to allow the smoother flow of mechanical energy away from the supported equipment.
- Upgraded foot to floor interface with inverted frostrum and cone spike.
- VRDC (Vectored Resonance Deflection Channels) incorporated into the underneath of each shelf module.



Modular Design



Natural Bamboo



Dark Bamboo

• See Bamboo Colour Information

WHAT HI-FI?
AWARDS 2018

Accessories

Best equipment rack

Atacama Evoque Eco 60-40 SE

WHAT HI-FI?
AWARDS 2017

Accessories

Best equipment rack

Atacama Evoque Eco 60-40 SE

WHAT HI-FI?
AWARDS 2016

Accessories

Best equipment rack

Atacama Evoque Eco 60-40 SE

WHAT HI-FI?
AWARDS 2015

Accessories

Best equipment rack

Atacama Evoque Eco 60-40 Special Edition

WHAT HI-FI?
AWARDS 2019

Accessories
Investment grade
Atacama Evoque 60-40 SE2

Atacama

EVOQUE ECO 60-40 SE2 HiFi Rack

WHAT HI-FI?
AWARDS 2020

BEST EQUIPMENT RACK
Atacama Evoque 60-40 SE2

- Features as Evoque Eco 60-40 Special Edition with the following upgrades/additions:-
- 5mm longer overall legs than Evoque Special Edition leg options.
- Contoured edges to the two side faces of each bamboo module designed to break up standing waves within the shelf.
- Upgraded premium mechanically tuned brass spikes.
- AVRDC (Advanced Vektored Resonance Deflection Channels) incorporated into the underneath of each shelf module.

WHAT HI-FI?
SOUND AND VISION



Gloss Black/ Natural
Bamboo Finish

WHAT HI-FI?
AWARDS 2021

BEST EQUIPMENT RACK

Atacama Evoque Eco
60-40 SE2



Modular
Design



WHAT HI-FI?
AWARDS 2022

BEST EQUIPMENT RACK

Atacama Evoque
Eco 60-40 SE2

WHAT HI-FI?
AWARDS 2023

BEST EQUIPMENT
RACK

ATACAMA EVOQUE
ECO 60-40 SE2



Natural Bamboo



Dark Bamboo

- See Bamboo Colour Information

Atacama

EVOQUE ECO DESIGN EDITION HiFi & AV Supports

- Design Editions are special, hand crafted versions of the award winning Evoque Eco:-

35-40 (14-16 Design Edition)

60-40 (24-16 Design Edition)

110-40 (44-16 Design Edition)

- Atacama Evoque Design Edition Bamboo modules are created by our top craftsmen then given a special, unique multi layered finish.
- Each complete rack is supplied as a matched set and is available as a compact, single or double width support.
- For non UK countries, the precise specification may differ to those stated. Please check with your local stockist for details.



Satin Black Legs/ *Design Edition Bamboo Finish

Evoque Eco 24-16 Design Edition

*See Bamboo Colour Information



Evoque Eco 14-16 Design Edition



Evoque Eco 44-16 Design Edition

Atacama

EVOQUE ECO 65-60 SE2 Reference Series HiFi Rack

- Features as Evoque Eco 60-40 Special Edition with the following upgrades/ additions:-

- 5mm longer overall legs than Evoque Special Edition leg options.

- Contoured edges to the two side faces of each bamboo module designed to break up standing waves within the shelf.

- Upgraded Reference quality mechanically tuned stainless steel spikes.

- AVRDC (Advanced Vected Resonance Deflection Channels) incorporated into the underneath of each shelf module.

- Extra large 65cm wide, 60cm deep dimensions.

- 50% increase in weight carrying capacity over other Evoque types.



Gloss Black/ Natural Bamboo Finish

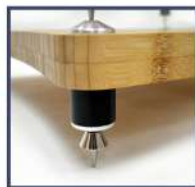

Modular Design



Natural Bamboo



Dark Bamboo

• See Bamboo Colour Information

Evoque Reference leg component description (detailed cut out)

Virtually every part of a Evoque leg is built around performance, not just supporting the Bamboo shelves!

Designed to allow a smooth transmission of mechanical energy away from the supported electronics, each shelf leg height option incorporates a tuning weight allowing dissipating energy a free flowing exit path to the floor.

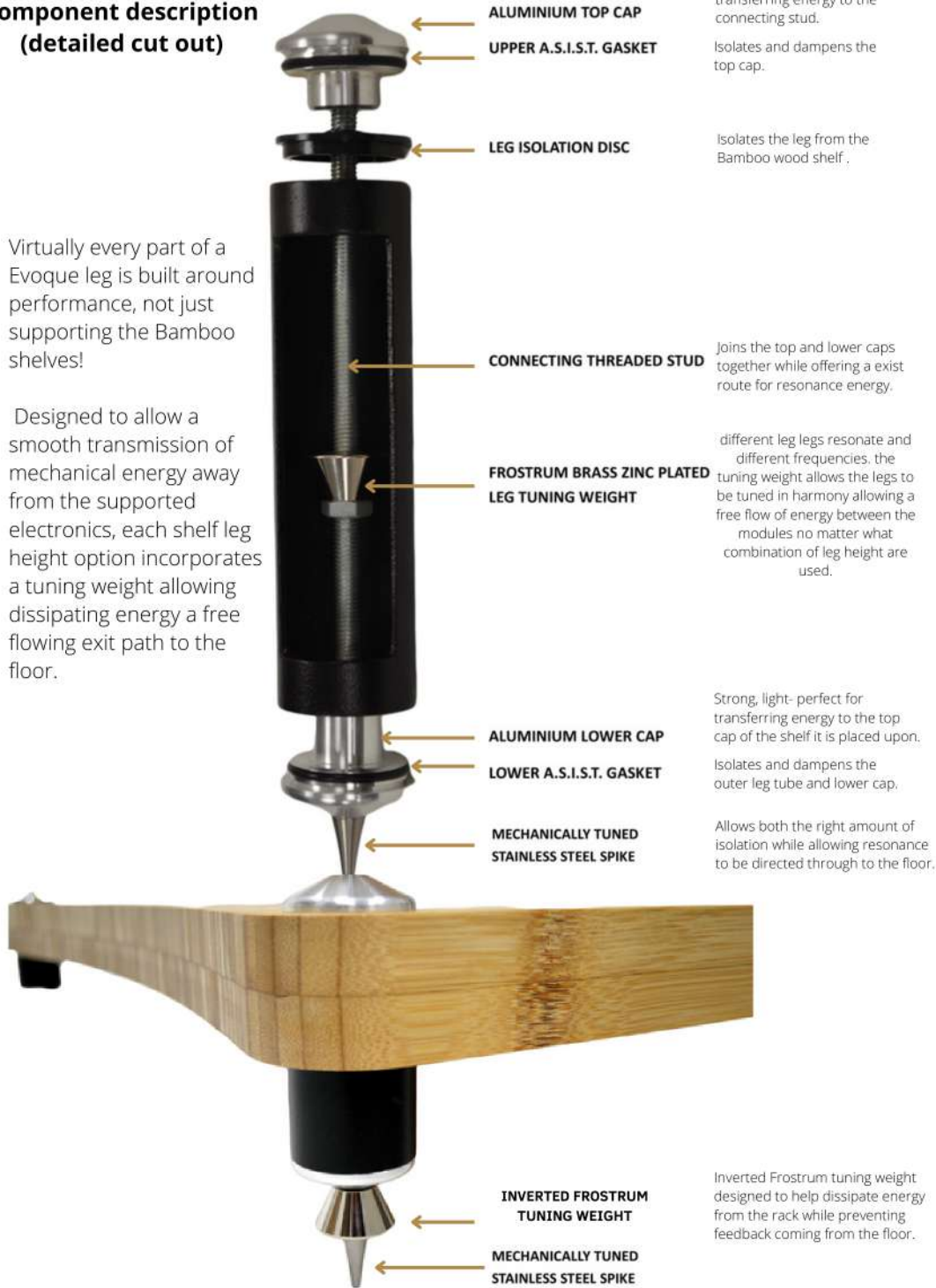

Atacama

ELITE ECO 24 REFERENCE HiFi Rack

- Next generation all 40mm solid bamboo design.
- Brass/ Zinc plated micro spike isolation spikes fitted to each shelf modules
- Inverted frostrum foot components included with base modules.
- Very high 80KG (176 lbs) load capacity per module.
- 3D-AVRDC (Three Dimensional Advanced Vected Resonance Deflection Channels) incorporated into each shelf module.
- Vinyl storage module available if required. (See sepearte product listing),



WHAT HI-FI?
SOUND AND VISION



August 2023

Natural Bamboo Finish



Modular
Design



- See Bamboo Colour Information

Atacama

ELITE ECO 24 REFERENCE HiFi Rack

- Three internal leg heights available; any combination can be specified.
- Compatible with both portrait or landscape style Atacama cable management systems.
- All modules can be adjusted independently to ensure accurate leveling.
- Maximum overall weight capacity of 250KG (551 lbs)
- 5 Star Award Winning Design(What HiFi Sound & Vision Magazine August 2023)
- Made in Great Britain



WHAT HI-FI?
SOUND AND VISION



August 2023

Dark Bamboo Finish

3D-A.V.R.D.C.

Three Dimensional Advanced
Vectored Resonance
Deflection Channels

- See Bamboo Colour Information



Atacama

ELITE ECO 24 2 Shelf Vinyl Storage Module

- Next generation all 40mm solid bamboo design.
- Inverted frostrum foot components included on the base panel.
- Vinyl Storage modules can be stacked if required.
- Very high 80KG (176 lbs) load capacity per level.
- Features 3D-AVRDC (Three dimensional Advanced Vectored Resonance Deflection Channels)
- Standard Elite Eco 24 shelf modules can be placed on top of the module if required.



Natural Bamboo Finish

WHAT HI-FI?
SOUND AND VISION



August 2023



Modular Design.
Extra shelf modules can be added for hifi component storage.



- See Bamboo Colour Information

Atacama

ELITE ECO 24 2 Shelf Vinyl Storage Module



WHAT HI-FI?
SOUND AND VISION



August 2023

Dark Bamboo Finish



Modular Design.
Extra shelf modules
can be added for hifi
component storage.



• See Bamboo Colour Information

Atacama

Monoplinth 60/65 SE Mono Block Supports



Natural Bamboo Finish



Dark Bamboo Finish



Designed primarily to support mono block amplifiers, Atacama **Monoplinth Eco 60/65 SE** are supplied in pairs (singles are available upon request) and use mechanical resonance technology developed from the multi-award winning Atacama Evoque Eco Special Edition series of hifi supports.



Atacama

UNIVERSAL CABLE MANAGEMENT SYSTEMS

the Universal CM panel range allows cable management to be added to most combinations of our modular furniture. Available in both portrait or landscape configuration.

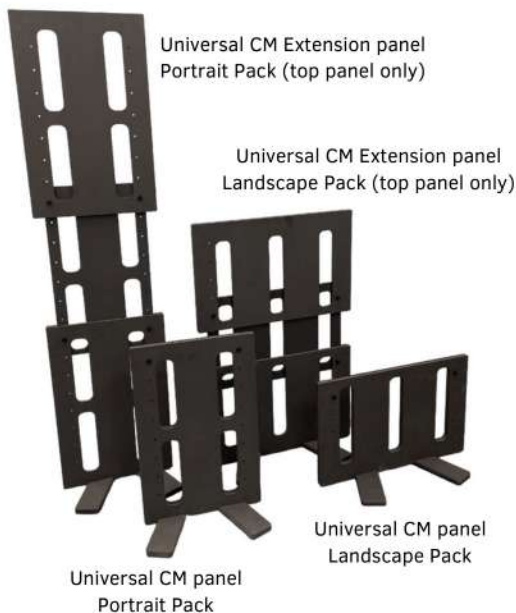

Universal Cable Management Panel Range

- Universal CM panel Portrait Pack
- Universal CM extension panel Portrait
- Universal CM panel Landscape Pack
- Universal CM extension panel Landscape

The Universal Cable Management Panel range is a versatile and adjustable solution for reducing the impact of unsightly cabling when using AV and HiFi furniture.

The main **portrait pack** (380mm wide) can accommodate racks from 600mm to 1050mm in height. If more height is needed, a third **extension panel** can be purchased separately allowing an increased height range of 1190mm to 1545mm.

The main **landscape pack** (580mm wide) can accommodate racks from 390mm to 645mm in height. If more height is needed, a third **extension panel** can be purchased separately allowing an increased height range of 785mm to 910mm.





APOLLO TECHNICAL DIMENSIONS

APOLLO STORM 6 FOUR SHELF MODULAR HI-FI SUPPORT

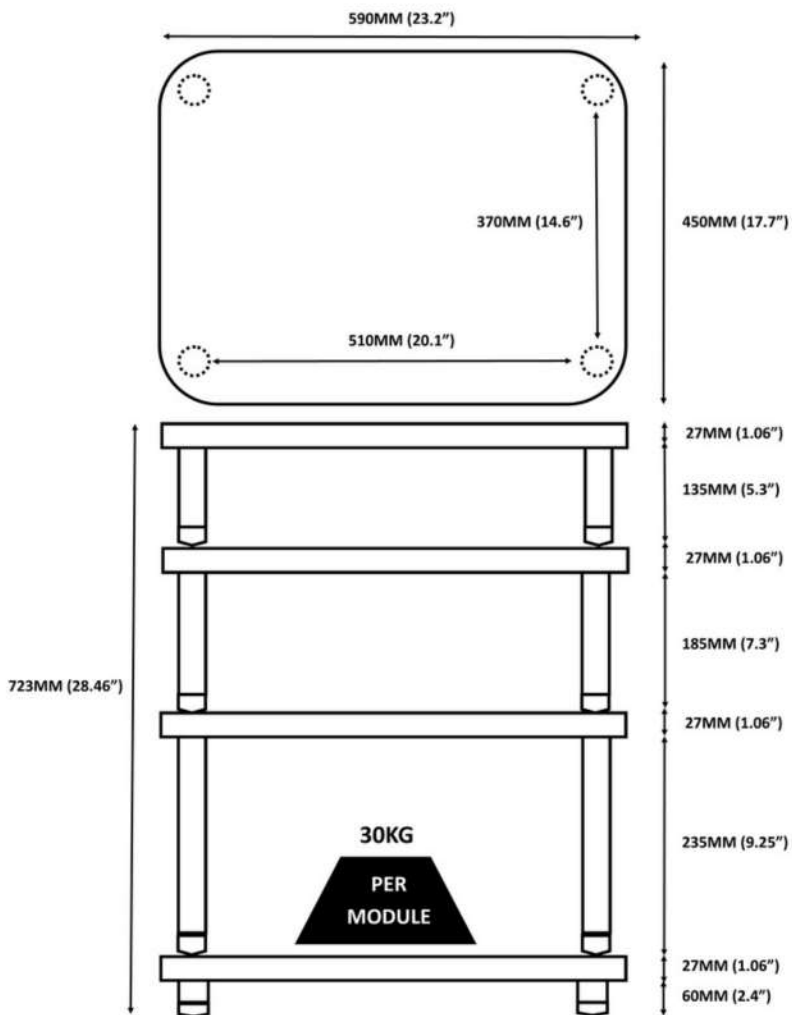

Maximum number of modules 5
Maximum overall height 1255mm (51")



APOLLO STORM 6 2 SHELF VINYL STORAGE MODULE

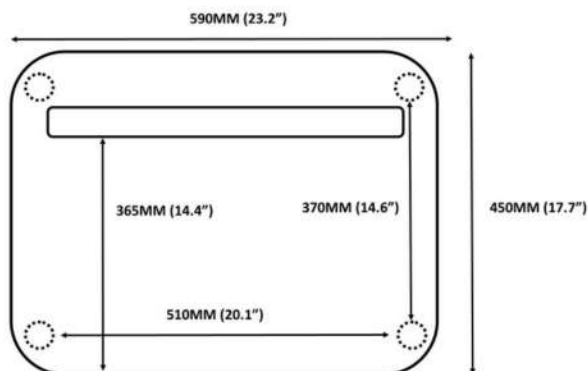

ADDITIONAL STANDARD APOLLO STORM 6 SHELF MODULES CAN BE PLACED ON TOP OF THE APOLLO STORM 6 2 SHELF VINYL STORAGE MODULE.
RECORD STOP CAN BE REMOVED IF MORE DEPTH IS REQUIRED.

35KG

**PER
SHELF**

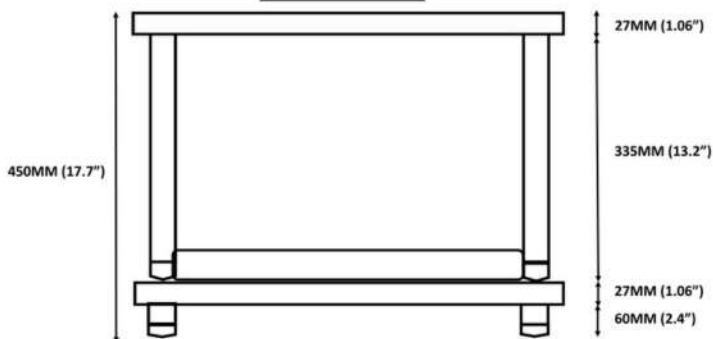



Apollo Storm 10 modular support

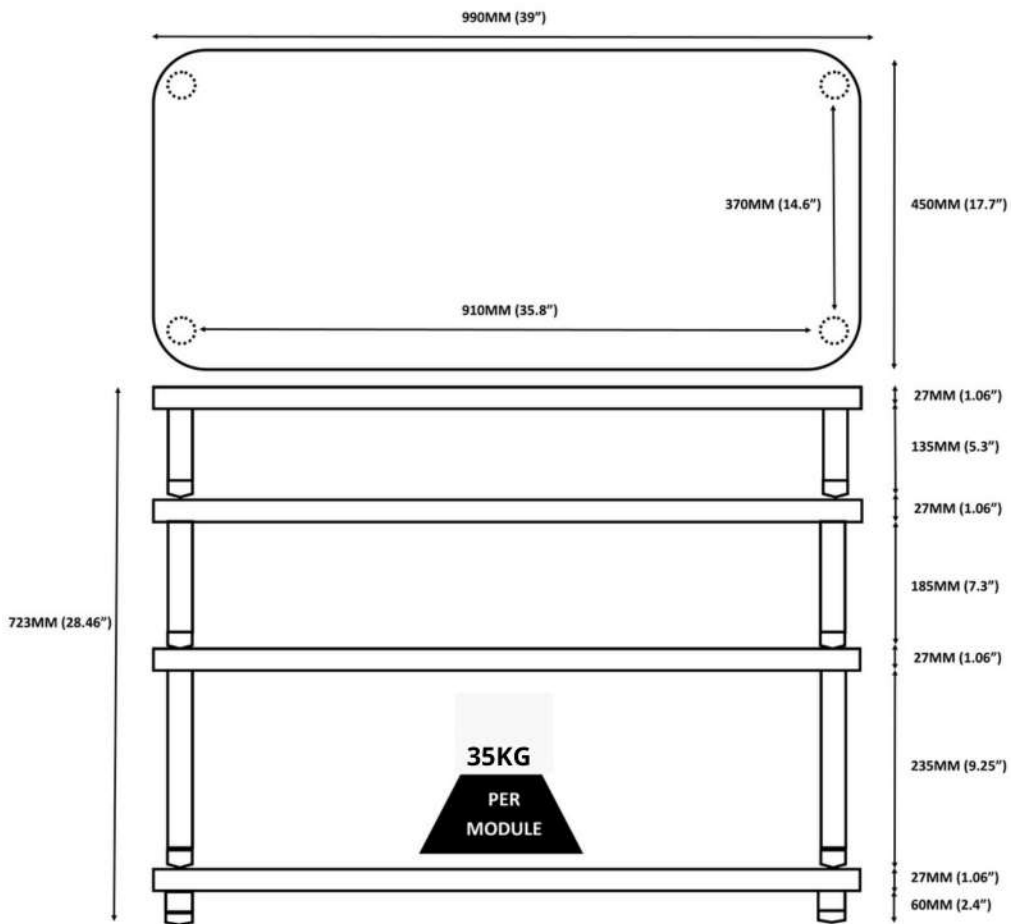

Maximum number of modules 6
Maximum overall height 1255mm (50")



APOLLO STORM 10 AV SUPPORT

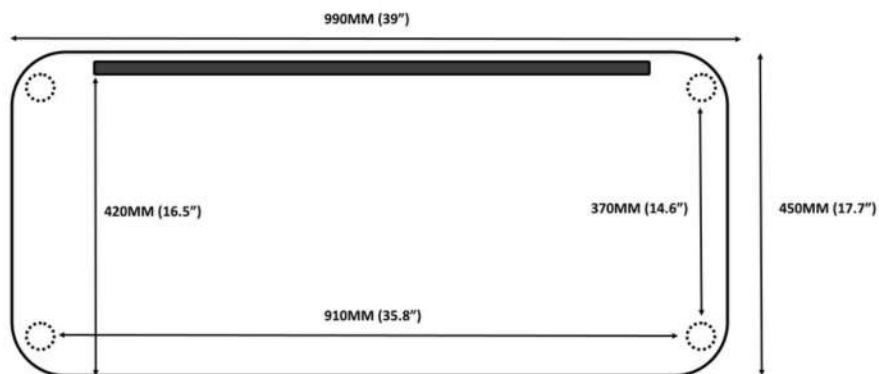

ADDITIONAL STANDARD APOLLO STORM 10 SHELF MODULES CAN BE PLACED ON TOP OF THE APOLLO STORM 10AV.

CABLE MANAGEMENT PANEL CAN BE REMOVED IF MORE DEPTH IS REQUIRED.

35KG

**PER
SHELF**



Maximum number of additional single modules 5
Maximum overall height 1255mm (50")

ATACAMA TECHNICAL DIMENSIONS

ERIS 2 ECO 5.0 HIFI

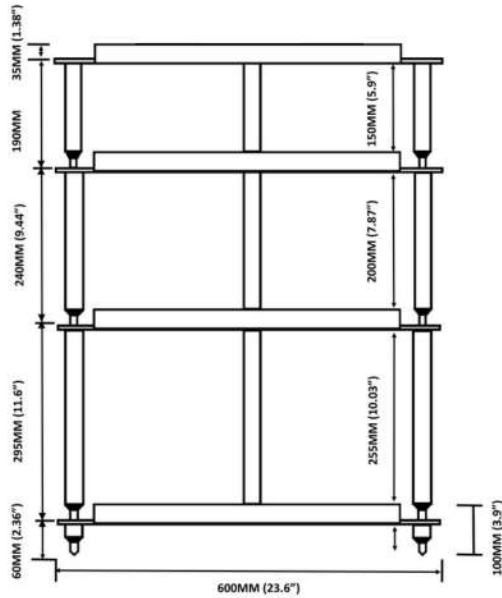
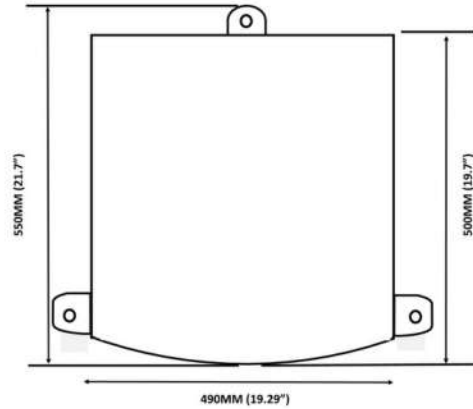

Eris Eco 5.0 capacity 30 kg (66lbs) per shelf

Maximum number of modules per rack :-
1 x 2 Shelf Base Module, 3 x single shelf modules

6 modules

**ATACAMA EVOQUE 35-40
EVOQUE 14-16 DESIGN EDITION**

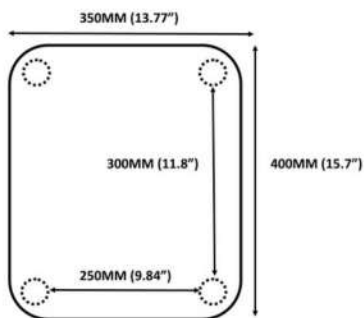

**ATACAMA EVOQUE 60-40
EVOQUE 24-16 DESIGN EDITION**

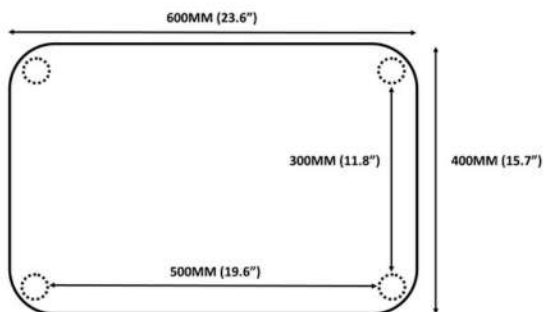

Maximum overall height not to exceed 1255MM (50")

**ATACAMA EVOQUE 110-40
EVOQUE 44-16 DESIGN EDITION**

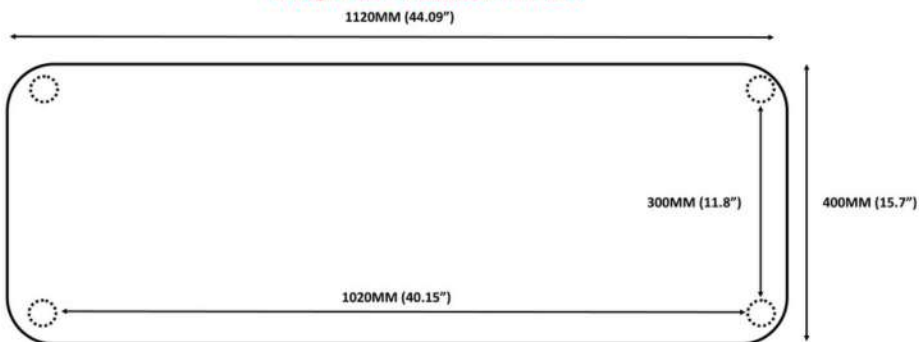

LEG HEIGHT OPTIONS FOR EVOQUE 35-40, 14-16, 60-40, 24-16, 110-40 & 44-16

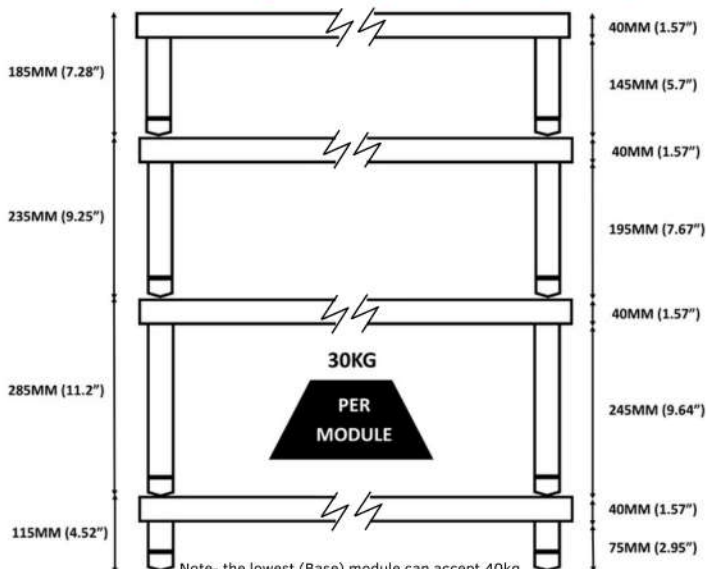

Note- the lowest (Base) module can accept 40kg providing the additional 10kg load is deducted from the storage weight of a module stacked above it.

ATACAMA EVOQUE 60-40 SPECIAL EDITION MODULAR HI-FI SUPPORT

Evoque Eco 60-40 Special Edition

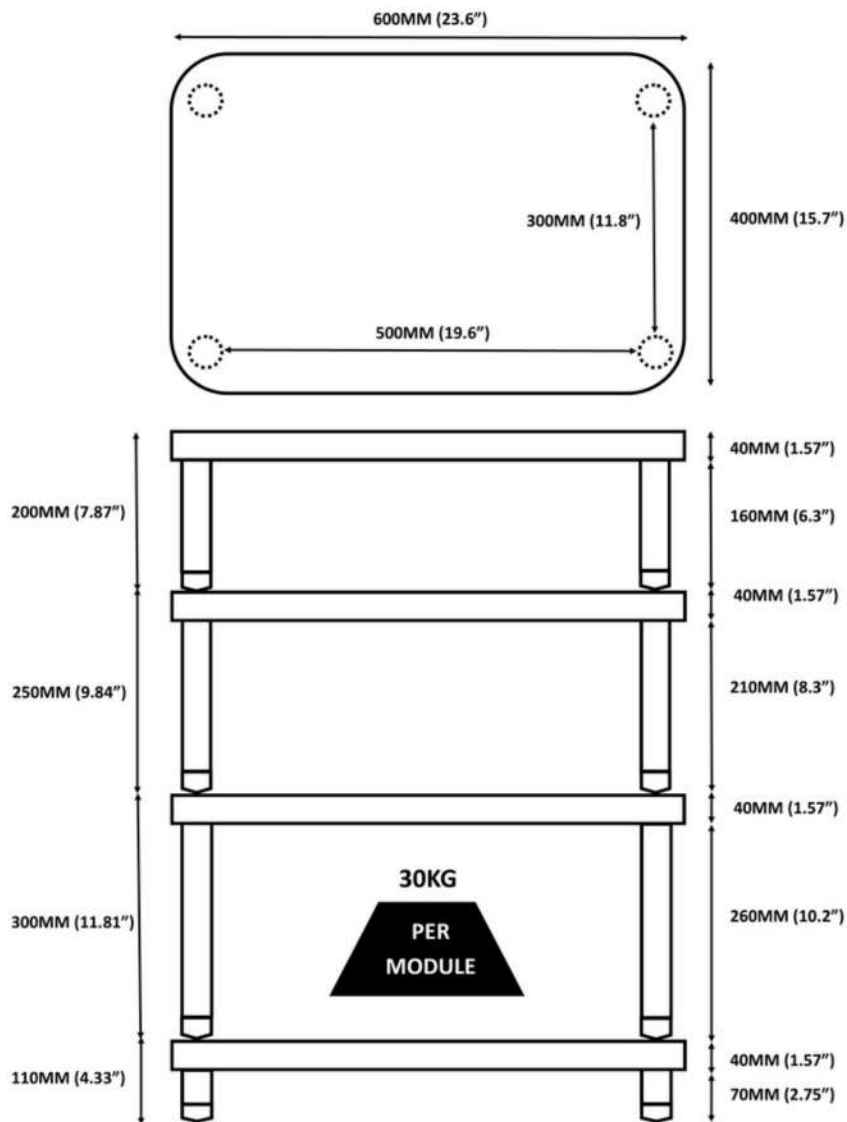

Maximum overall height not to exceed 1255MM (50")

Note- the lowest (Base) module can accept 40kg providing the additional 10kg load is deducted from the storage weight of a module stacked above it.

ATACAMA EVOQUE 60-40 SE2 MODULAR HI-FI SUPPORT

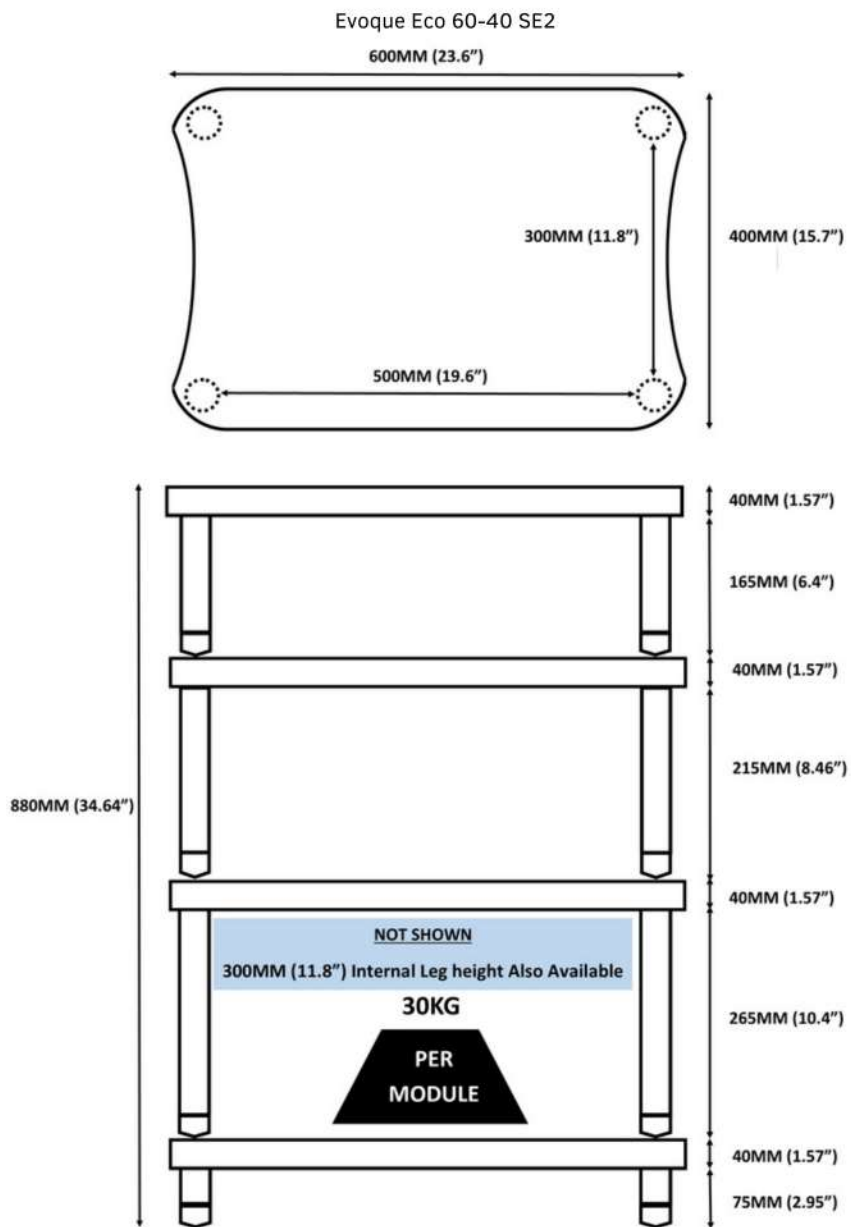

Maximum overall height not to exceed 1255MM (50")

Note- the lowest (Base) module can accept 40kg providing the additional 10kg load is deducted from the storage weight of a module stacked above it.

ATACAMA EVOQUE 65-60 SE2 MODULAR HI-FI SUPPORT

Reference Series

Evoque Eco 65-60 SE2 Reference Series

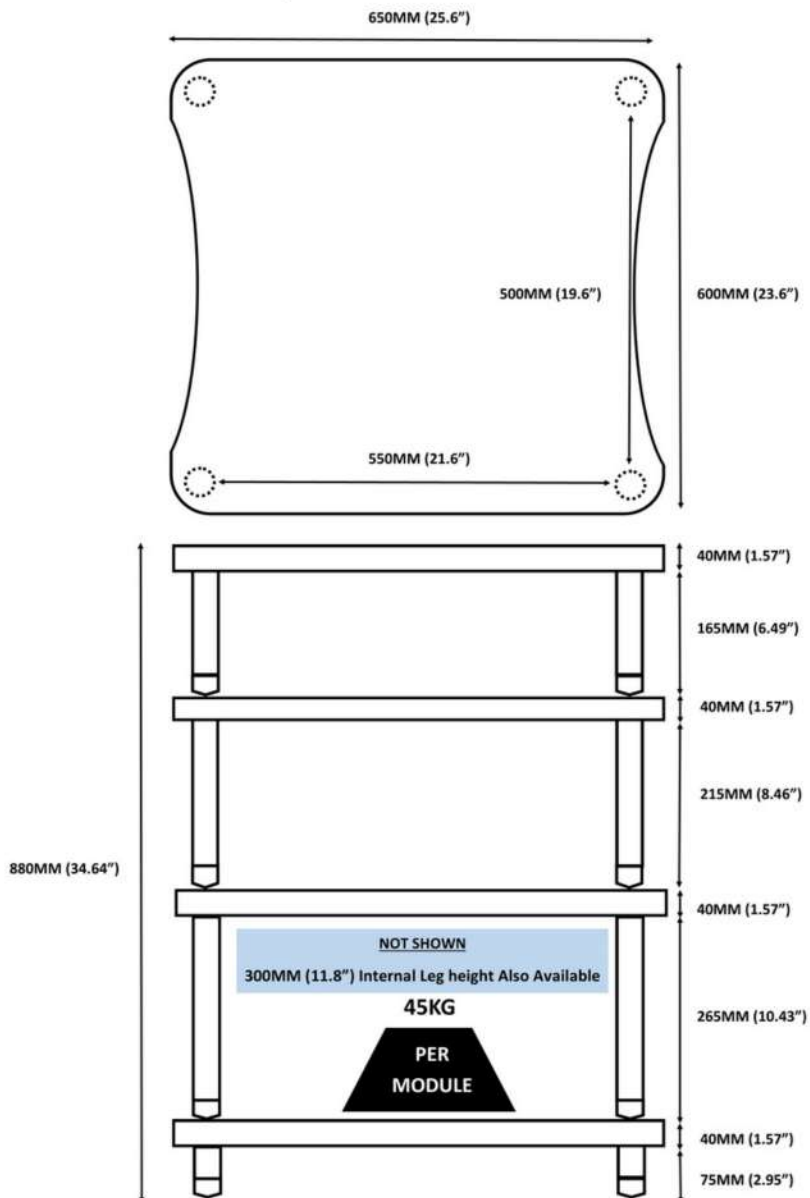

Maximum overall height not to exceed 1255MM (50")

Note- the lowest (Base) module can accept 40kg providing the additional 10kg load is deducted from the storage weight of a module stacked above it.

ATACAMA ELITE ECO 24 MODULAR HI-FI SUPPORT

Reference Series

Elite Eco 24 Reference Series

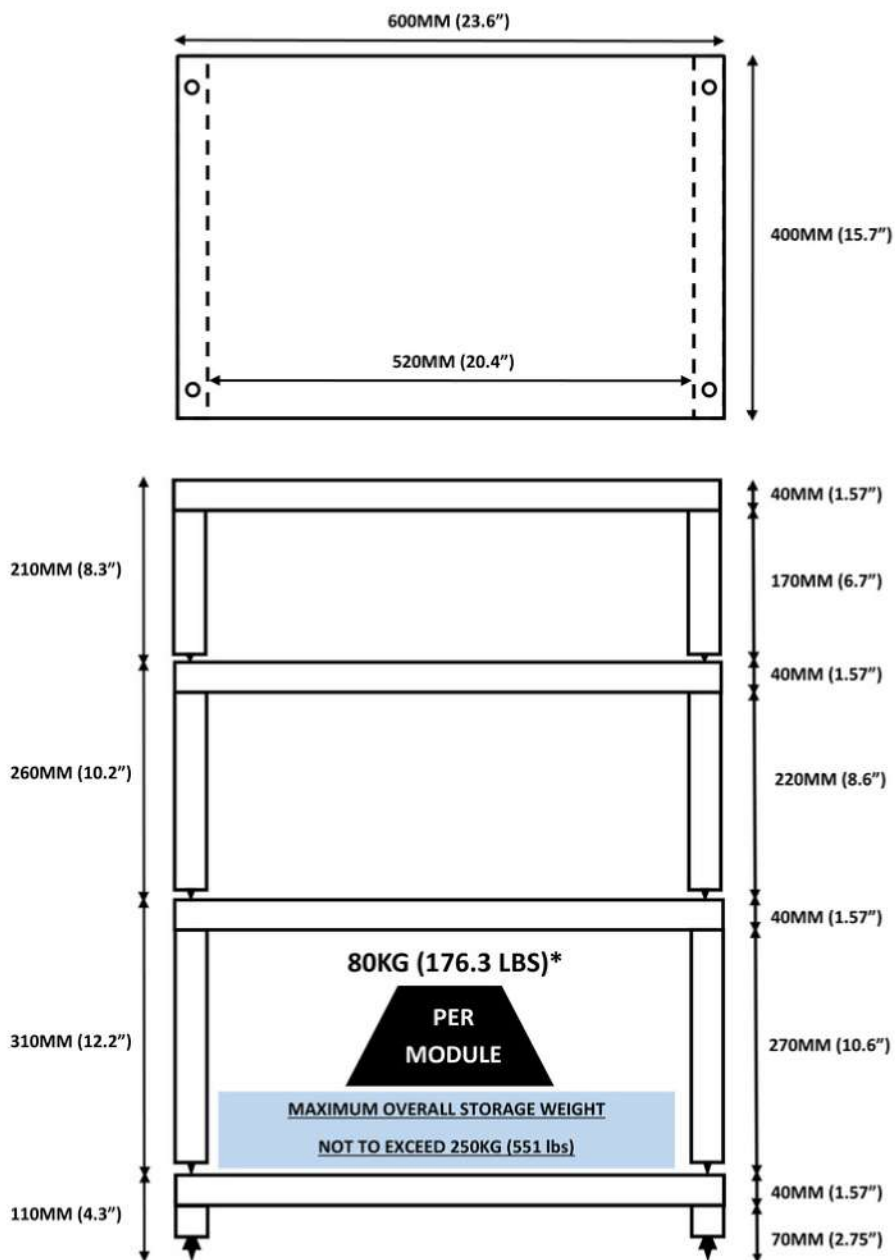

Maximum overall height not to exceed 1255MM (50")

ATACAMA ELITE ECO 24 2 SHELF VINYL STORAGE MODULE

Reference Series

Elite Eco 24 2 shelf Vinyl Storage Module Reference Series

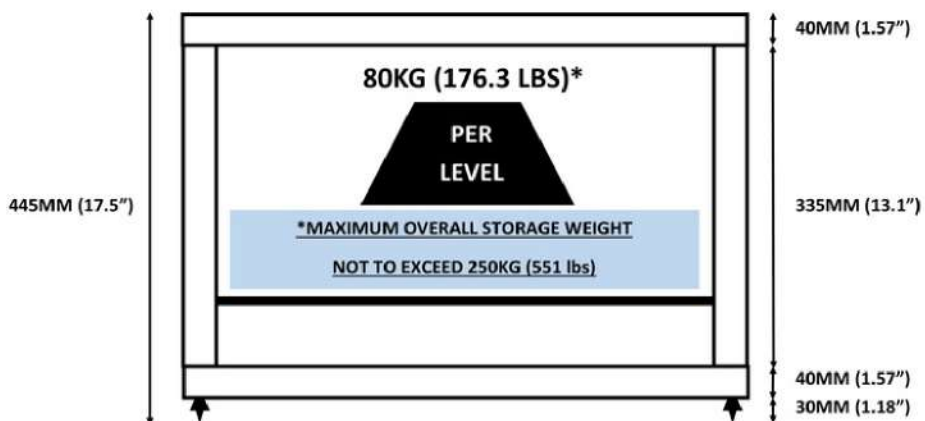
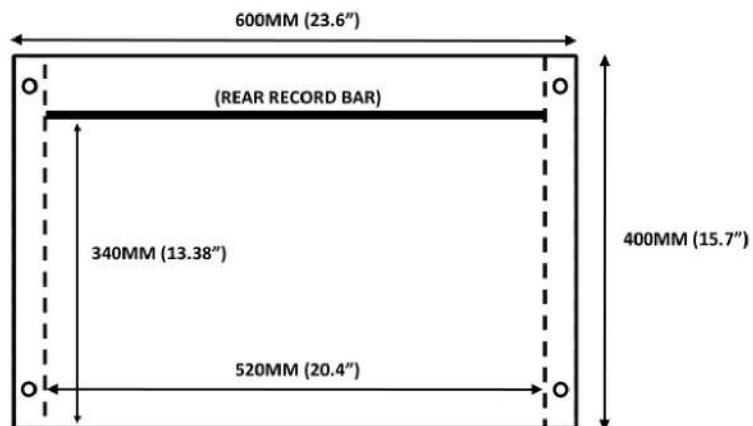

NOTE- THE REAR RECORD STOP BAR CAN BE REMOVED IF THE FULL DEPTH OF THE LOWER SHELF NEEDS TO BE USED FOR EQUIPMENT STORAGE.

If adding extra single shelf modules, Maximum overall height not to exceed 1255MM (50")

UNIVERSAL CABLE MANAGEMENT SYSTEMS

UNIVERSAL CABLE MANAGEMENT PANEL (PORTRAIT)

UNIVERSAL CABLE MANAGEMENT EXTENSION PANEL (PORTRAIT)

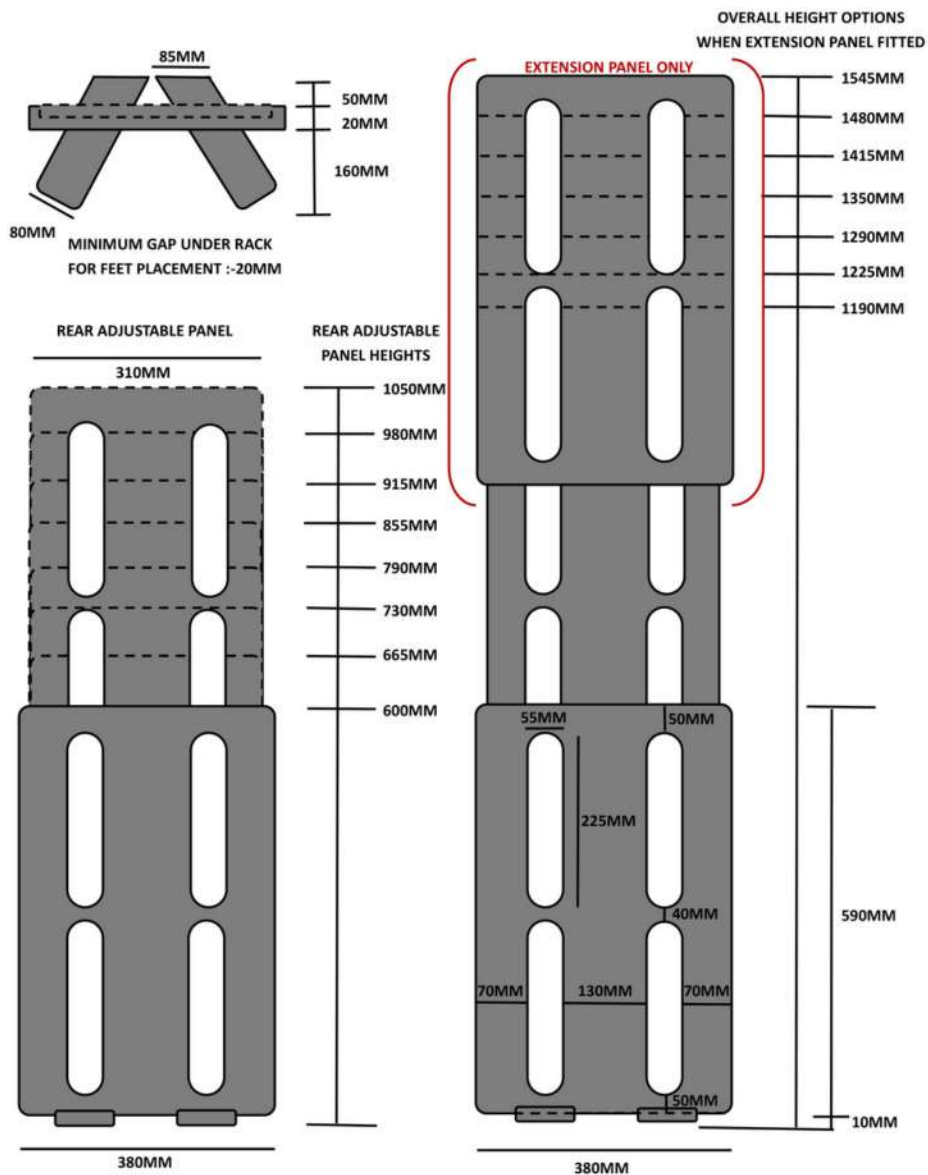

UNIVERSAL CABLE MANAGEMENT SYSTEMS

UNIVERSAL CABLE MANAGEMENT PANEL (LANDSCAPE)

UNIVERSAL CABLE MANAGEMENT EXTENSION PANEL (LANDSCAPE)

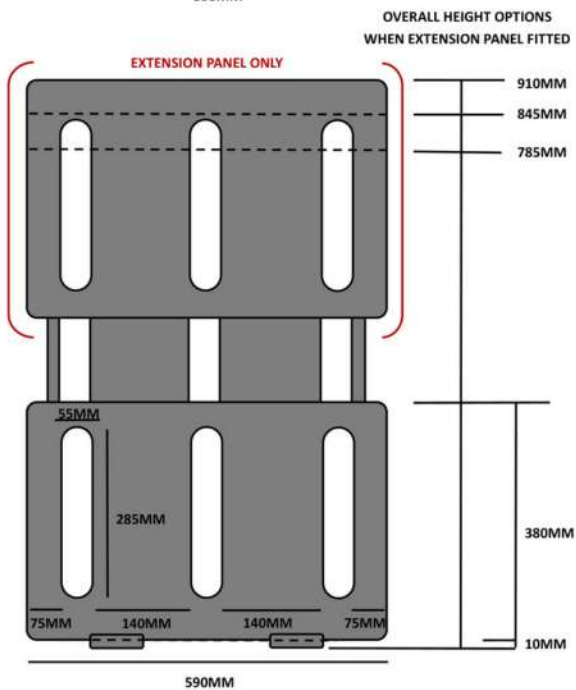
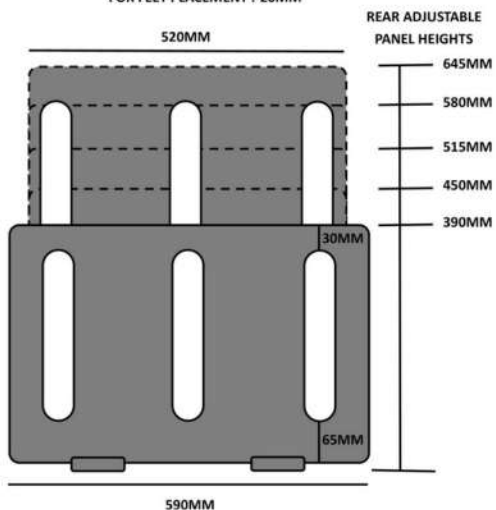
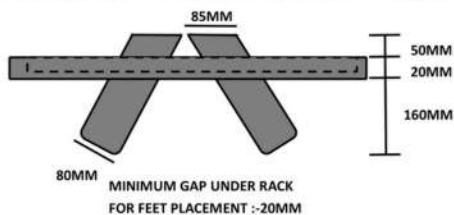

ATACAMA Monoplinth 65/60 SE

Atacama Monoplinth Series (Supplied in Pairs)

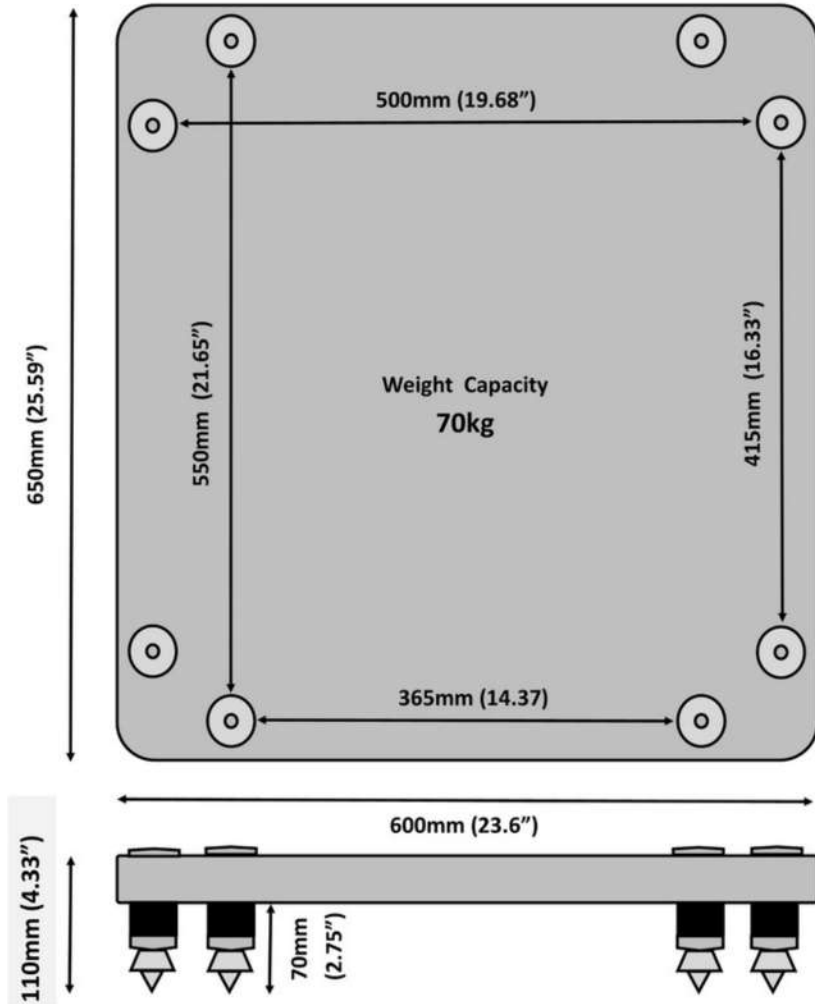

Weight Capacity 70 KG (154 lbs)

Leg Pack Information

Leg packs are identified and listed by the INNER storage height, or in the case of the shortest leg length available, as a base module. There will be some additional adjustment available via the leg spikes.

All racks should use a base module as the lowest level of storage to avoid the legs splaying and to maximize storage weight capacity. Our modular racks have leg height replacement packs available should your storage height requirement change at a later date. Most models have a extra tall (295mm-300mm depending on rack type) leg replacement option available which can be purchased separately.

IMPORTANT-Bamboo & Oak Colour Information

Bamboo and Oak are natural materials so colour, texture, grain and age will give a variable appearance to each shelf. Because of this, adding extra shelving at a later date will introduce a batch /colour tonal difference. Where possible order your rack as a complete modular support with enough levels to fulfil possible future requirements in order to minimize this variation. There may be some darkening of the wood over time. This is normal and part of the materials maturing process. Colours and bamboo/ Oak grains shown in this brochure are examples of the final finishes. Due to print limitations, studio lighting and the variability of the final look of each wood shelf, to avoid disappointment do not attempt colour matching using the photographs shown to existing furniture. Each Bamboo and Oak shelf will have its own unique grain, colour and tonal balance which is part of the intrinsic beauty of natural woods and should not be viewed or treated as a defect.

Sambell Engineering Ltd
T/A Atacama Audio & Apollo Hifi
Winston Avenue
Croft
Leicestershire
LE9 3GQ
Tel:- 44-(0)1455 283251
email:- post@atacama-audio.co.uk

Atacama

Multi Media furniture Specialist

Speaker Stands

**WHAT HI-FI?
AWARDS 2018**

Accessories
Best speaker stand
Atacama Moseco 6

**WHAT HI-FI?
AWARDS 2017**

Accessories
Best speaker stand
Atacama Moseco 6

**WHAT HI-FI?
AWARDS 2016**

Accessories
Best speaker stand
Atacama Moseco 6

**WHAT HI-FI?
AWARDS 2015**

Accessories
Best speaker stand
Atacama Moseco 6

**WHAT HI-FI?
AWARDS 2014**

Accessories
Best speaker stand
Atacama Moseco 6

**WHAT HI-FI?

AWARDS 2023**

BEST SPEAKER
STANDS
**ATACAMA
MOSECO 6**

**WHAT HI-FI?

AWARDS 2022**

BEST SPEAKER STANDS
Atacama Moseco 6

**WHAT HI-FI?

AWARDS 2021**

BEST SPEAKER STANDS
Atacama Moseco 6

**WHAT HI-FI?

AWARDS 2020**

BEST SPEAKER STANDS
Atacama Moseco 6

**WHAT HI-FI?

AWARDS 2019**

Accessories
Best speaker stands
Atacama Moseco 6



Featuring the Multi-Award Winning Moseco Series

((apollo))

Setting the standard since 1975

And Introducing
Apollo Cyclone Series



Introduction

Atacama offers a wide range of British designed and manufactured speaker stands with a choice of colours, dimensions and styles to satisfy most requirements.

The Apollo Cyclone series speaker stand features a natural solid oak base panel which helps minimize mechanical resonance and a 50.8mm centrally located tube that can be mass loaded to help tune the supported speakers.

Bringing value and adaptability to speaker stand design, the NeXXus Essential, HiFi Audio, CM (Cable Management) and Pro Studio specifications are available in a range of height options while offering an extensive range of top plate upgrades. NeXXus makes an excellent choice as it can support a wide range of popular speaker sizes. As with all Atacama speaker stands, performance can easily be tuned to the supported speakers sonic characteristics by increasing overall mass by part filling the twin columns with Atabites.

The SLX and Audition Series are professional quality stands which caters for larger bookshelf speakers where an increase in the base-plate footprint is required to ensure optimum stability. With a wide choice of heights options, these heavy-duty speaker stands are available in two colours and feature the new high-load trapezoidal gel pads as standard. SLX can except top spikes if preferred (cost option).

The HMS (high Mass Stand) Series is the audiophiles choice, incorporating a significant increase in mass loading capacity and designed with very high-quality speakers in mind. With over sized tubes and precision carbon steel laser cut top plates, the HMS speaker stand represent the pinnacle of an all metal design.

Moseco and Moseco XL Series are the designer models in the Atacama range, using both acoustic and environmentally friendly Bamboo to enhance the listening experience. Moseco has been awarded both 5 stars and BEST SPEAKER STANDS all the way through from 2014 to 2023 in What Hi-Fi? Sound & Vision magazine, so don't just take our word for it!

Centre Channel speakers require dedicated stands as they tend to be of unconventional dimensions. The Moseco CC Series provides that solution and are available in a wide range of height, colour and bamboo finish options. Want a all steel centre channel speaker stand? The new Ensign series may be just what you are looking for.

All Atacama speaker stands are supplied with isolation spikes as standard on the base plates/panels (do not worry if you have delicate floor coverings, just be sure to include spike shoes which will protect your floor) and can be mass loaded with Atabites designed to help tune your speakers to match the room acoustics.

Contents

Apollo Cyclone Series	Oak based speaker stands
NeXXus Series	Performance & value speaker stands
Moseco Series	Multi-award winning bamboo based speaker Stands
SLX & Audtion Series	Professional speaker stands
HMS Series	Reference speaker stands
Moseco XL Series	Extra large bamboo based speaker stands
Moseco CC Series	Centre channel speaker stands
Ensign CC Series	All steel centre channel speaker stands

Accessories

Technical Chart



- Spike Shoes
- Isolation Gel Pads
- Mass Loading Plates
- Top Plate Spike Packs
- Base Plate Spike Packs
- Atabite Mass Loading Filler



((apollo))

Setting the standard since 1975

by

Atacama



Apollo Cyclone Series

Dimensions

Top plate

(Set up 1) Width, Depth 150mm (5.9") x 200mm (7.9")

(Set up 2) Width, Depth 200mm (7.9") x 150mm (5.9")

Base Panel Width, Depth 240mm (9.4") x 300mm (11.8")

Height Options

(Excluding Spikes & Domed Gel Pads)

Cyclone 5 515mm (20.3")

Cyclone 6 615mm (24.2")

Cyclone 7 715mm (28.1")

Supplied in pairs.

Add approx. 20mm to height when spikes are fitted.



Cyclone 6

Colour Options

Column

Silk Black (Standard)

Glazier White (Standard)

Base Panel Options

Natural Oak Finish (Standard)

Dark Oak Finish (Cost Option)

Weight Capacity

7.5kg (16.5lbs), 10KG (22lbs) if part filled with Atabites.



Cyclone 6, Glazier White, Natural Oak Finish- Dark Oak Finish

Cyclone 6 Silk Black, Natural Oak Finish- Dark Oak Finish

NeXXus Series

With over 200 different combinations of height, colour, specification and top plate sizes, NeXXus brings maximum adaptability to meet your speaker support requirements!

Essential specification, offering great value, these stands are ideal for small to medium sized bookshelf speakers or surround sound applications.

Each stand features:-

2 x 50.8mm (2") vertical tubes

Can support speakers up to 15kg (33.06 lbs)

Domed top plate gel pads

Maximum Atabite filler capacity (600 version example per pair) 16.8kg (37 lbs)



NeXXus 500 Essential
Diamond White Finish

HiFi Audio specification, perfect for the experienced hifi enthusiast with medium to high end hifi equipment looking to maximize domestic speaker performance as well as offering a practical, stable speaker support.

Each stand features:-

1 x 76.2mm (3") & 1 x 50.8mm (2"), vertical tubes

Can support speakers up to 22.5kg (49.06 lbs)

Domed top plate gel pads

Maximum Atabite filler capacity (600 version example per pair) 29.65kg (65.3 lbs)



NeXXus 600 HiFi Audio
Satin Black Finish

CM specification, with cable management and a mass loading capacity greater than Essential specification, these stands offer both performance and practicality.

Each stand features:-

1 x 76.2mm (3") & 1 x 50.8mm (2") with cable management, vertical tubes

Can support speakers up to 22.5kg (49.06 lbs)

Domed top plate gel pads

Maximum Atabite filler capacity (600 version example per pair) 21.25kg (48.8 lbs)



NeXXus 600 CM
Satin Black Finish

Pro Studio specification, for when only the best will do! Designed for professional studio applications, high end audiophile speakers or when active monitor speakers need supporting.

Each stand features:-

2 x 76.2mm (3") vertical tubes

Can support speakers up to 30kg (66.12 lbs)

High load trapezoidal gel pads

Maximum Atabite filler capacity (600 version example per pair) 42.5kg (93.7 lbs)



NeXXus 700 Pro Studio
Diamond White Finish

NeXXus Series

NeXXus **ESSENTIAL** Speaker Stands



Dimensions

Standard Top Plate (Width, Depth) 130mm (5.11") x 170mm (6.69")

Top Plates supplied with domed gel pads

Base Plate (Width, Depth) 260mm (10.2") x 365mm (14.37")

Overall Height Options

220mm (8.66"), 320mm (12.6"), 420mm (16.5"), 520mm (20.47"), 620mm (24.4"), 720mm (28.3"), 1020mm (40.14"). (Inclusive of floor spikes)

Weight capacity (per stand) 15g (33.6lbs)

Optional Top Plate Packs

Top plate pack dimensions (Width/Depth)

160mm x 220mm (6.29" x 8.66")

140mm x 210mm (5.51" x 8.26")

180mm x 140mm (7.08" x 5.51")

190mm x 305mm (7.48" x 12")

NeXXus speaker stands are supplied in pairs.

Available Colour Finishes

Satin Black (Standard)



Diamond White (Cost Option)



**Maximum Atabite
Capacity 16.8kg**



NeXXus Series

NeXXus HiFi AUDIO Speaker Stands



Dimensions

Standard Top Plate (Width, Depth) 130mm (5.11") x 170mm (6.69")

Top Plates supplied with domed gel pads

Base Plate (Width, Depth) 260mm (10.2") x 365mm (14.37")

Overall Height Options

220mm (8.66"), 320mm (12.6"), 420mm (16.5"), 520mm (20.47"), 620mm (24.4"), 720mm (28.3"), 1020mm (40.14"). (Inclusive of floor spikes)

Weight capacity (per stand) 22.5kg (49.6 lbs)

Optional Top Plate Packs

Top plate pack dimensions (Width/Depth)

160mm x 220mm (6.29" x 8.66")

140mm x 210mm (5.51" x 8.26")

180mm x 140mm (7.08" x 5.51")

190mm x 305mm (7.48" x 12")

NeXXus speaker stands are supplied in pairs.

Available Colour Finishes

Satin Black (Standard)



Diamond White (Cost Option)



NeXXus 600 HiFi AUDIO

Maximum Atabite
Capacity 29.6kg



NeXXus Series

NeXXus CM (Cable Management) Speaker Stands



NeXXus 700 CM



1 x Cable Management
50.6mm (2") Tube
1 x
76.2mm (3") Tube
Per Stand



NeXXus 600 CM

Dimensions

Standard Top Plate (Width, Depth) 130mm (5.11") x 170mm (6.69")

Top Plates supplied with domed gel pads

Base Plate (Width, Depth) 260mm (10.2") x 365mm (14.37")

Overall Height Options

520mm (20.47"), 620mm (24.4"), 720mm (28.3"), 1020mm (40.14").

(Inclusive of floor spikes)

Weight capacity (per stand) 22.5kg (49.6 lbs)

Optional Top Plate Packs

Top plate pack dimensions (Width/Depth)

160mm x 220mm (6.29" x 8.66")

140mm x 210mm (5.51" x 8.26")

180mm x 140mm (7.08" x 5.51")

190mm x 305mm (7.48" x 12")

NeXXus speaker stands are supplied in pairs.

Available Colour Finishes

Satin Black (Standard)



Diamond White (Cost Option)



Maximum Atabite
Capacity 29.6kg



Cable Management

NeXXus 500 CM

NeXXus Series

NeXXus PRO STUDIO Speaker Stands



Dimensions

Standard Top Plate (Width, Depth) 130mm (5.11") x 170mm (6.69")

Top Plates supplied with High Load Trapezoidal Gel Pads

Base Plate (Width, Depth) 260mm (10.2") x 365mm (14.37")

NeXXus 600 PRO STUDIO

Maximum Atabite
Capacity 42.5g



Overall Height Options

220mm (8.66"), 320mm (12.6"), 420mm (16.5"), 520mm (20.47"), 620mm (24.4"),
720mm (28.3"), 1020mm (40.14"). (Inclusive of floor spikes)

Weight capacity (per stand) 30kg (66lbs)

Optional Top Plate Packs

Top plate pack dimensions (Width/Depth)

160mm x 220mm (6.29" x 8.66")

140mm x 210mm (5.51" x 8.26")

190mm x 305mm (7.48" x 12")

NeXXus speaker stands are supplied in pairs.

Available Colour Finishes

Satin Black (Standard)



Diamond White (Cost Option)



Twin 76.2 mm (3") Diameter Tubes Per Stand



SLX & Audition Series



Audition 300



SLX 600
Satin Black



SLX & Audition Series

Height Options (Including Spikes & Gel Pads)

SLX 200	235mm (9.25")
SLX & Audition 300	335mm (13.19")
SLX & Audition 400	435mm (17.12")
SLX & Audition 500	535mm (21.06")
SLX & Audition 600	635mm (25")
SLX & Audition 700	735mm (28.9")
SLX 1000	1035mm (40.7")

Weight capacity SLX 15kg (33lbs),
Audition 20kg (44lbs) per stand. Supplied in pairs.

Dimensions

SLX Top Plate-Width 225mm (8.9") x Depth 225mm (8.9")
Audition Top Plate- Width 360mm (14.17") x Depth 225mm (8.9")

SLX Base Plate - Width 305mm (12") x Depth 305mm (12")
Audition Base Plate - Width 400mm (15.7") x Depth 305mm (12")

Note- The heights quoted include the supplied floor spikes and High Load Trapezoidal Gel Pads.

SLX Speaker stands can accept optional 6mm top spikes if required.

Available Colour Finishes



Satin Black
(Std)



Diamond White
(Cost Option)

**Optional
Top Plate
Spike Pack
(For SLX Only)**

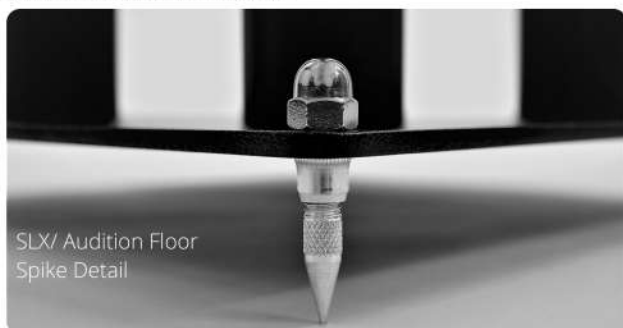

Moseco Series

WHAT HI-FI? AWARDS 2014

Accessories
Best speaker stand
Atacama Moseco 6

WHAT HI-FI? AWARDS 2015

Accessories
Best speaker stand
Atacama Moseco 6 Special Edition

WHAT HI-FI? AWARDS 2016

Accessories
Best speaker stand
Atacama Moseco 6

WHAT HI-FI? AWARDS 2017

Accessories
Best speaker stand
Atacama Moseco 6

WHAT HI-FI? AWARDS 2018

Accessories
Best speaker stand
Atacama Moseco 6

WHAT HI-FI? AWARDS 2019

Accessories
Best speaker stand
Atacama Moseco 6

WHAT HI-FI? AWARDS 2020

BEST SPEAKER STANDS
Atacama Moseco 6

WHAT HI-FI? AWARDS 2021

BEST SPEAKER STANDS
Atacama Moseco 6

WHAT HI-FI? AWARDS 2022

BEST SPEAKER STANDS
Atacama Moseco 6

WHAT HI-FI? AWARDS 2023

BEST SPEAKER STANDS
ATACAMA MOSECO 6

Available Colour Finishes

Satin Black (Standard)

Diamond White (Cost Option)

Gloss Black Front Column/
Satin Black Rear Column (Cost Option)

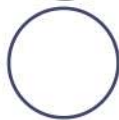

Moseco 6

Bamboo Base Colour Options

Natural Bamboo Finish (Standard)
Dark Bamboo Finish (Cost Option)

Weight Capacity 7.5kg (16.5lbs) per stand, 10KG (22lbs) if part filled with Atabites. Supplied in pairs.

Height Options

Moseco 5 515mm (20.3") Height
Moseco 6 615mm (24.2") Height
Moseco 7 715mm (28.1") Height
Moseco 10 1015mm (40") Height

WHAT HI-FI? SOUND AND VISION



Dimensions

Standard Top Plate- Width 130mm (5.2") Depth x 170mm (6.7")
Base Panel -Width 240mm (9.45") Depth x 280mm (11")

Optional Top Plate packs - sold separately

Top plate pack dimensions (Width/Depth)
160mm x 220mm (6.29" x 8.66")
140mm x 210mm (5.51" x 8.26")
180mm x 140mm (7.08" x 5.51")



Note- The heights quoted excludes the supplied floor spikes and Isolation gel pads. Add 15mm to allow for these.
Moseco speaker stands are supplied in pairs. Bamboo is a natural material so the underlying colour, texture, grain and age will make each pair of speaker stands aesthetically unique.

HMS Series

HMS 2X Specifications

Height Options

HMS 2X 600 Height 607mm (23.9")
Excluding Floor Spikes & High Load Gel Pads

Dimensions

Top Plate Dimensions:- Width 200mm (7.87") Depth 225mm (8.85")

Base Plate Dimensions:- Width 300mm (11.8") Depth 335mm (13.18")

Weight capacity 42kg (92.6lbs) per stand.

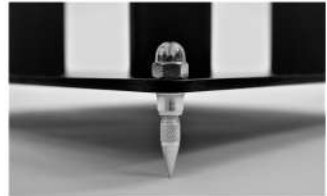

Available Colour Finish

Satin Black



Note- The height quoted excludes the supplied floor spikes and high load Isolation gel pads. Add 15mm to allow for these.

HMS speaker stands are supplied in pairs.

Moseco XL Series

Moseco XL Series

Moseco XL500 520mm (20.47") Height

Moseco XL600 620mm (24.40") Height

Available Colour Finishes

Satin Black (Standard)



Natural



Dark



Bamboo Base Colour Options
Natural Bamboo (Standard)
Dark Bamboo Finish (Cost Option)



Moseco XL 600

Dimensions

Top Plate- Width 200mm (7.8") x Depth x 275mm (10.75")

Base Plate -Width 275mm (10.75") x Depth 350mm (13.78")

Weight Capacity 20kg (44lbs) per stand. Moseco XL speaker stands are supplied in pairs.

Note- The heights quoted excludes the supplied floor spikes and Domed Gel Pads (add 15mm to the overall height to allow for these).

Moseco XL speaker stands are supplied in pairs. Bamboo is a natural material so the underlying colour, texture, grain and age will make each pair of speaker stands unique.

Centre Channel Speaker Stand

Moseco CC Series

Available Colour Finishes

Satin Black (Standard)



Diamond White (Cost Option)



Moseco CC Series

Height Options

200- 215mm (8.5")	Height
300- 315mm (12.4")	Height
400- 415mm (16.3")	Height
500- 515mm (20.3")	Height
600- 615mm (24.2")	Height

Weight capacity 25kg (55lbs).
Supplied as single stands.

Bamboo Base Colour Options

Natural Bamboo Finish (Standard)

Dark Bamboo Finish (Cost Option)



Moseco CC01-400



Natural & Dark Finishes

Dimensions

Moseco CC01 Top Plate Dimensions Width 400mm (15.7") Depth 180mm (7.1")

Moseco CC02 Top Plate Dimensions Width 475mm (18.7") Depth 210mm (8.3")

Moseco CC03 Top Plate Dimensions Width 550mm (21.65") Depth 250mm (9.8")

Bamboo Base Dimensions (All Models) - Width 600mm (23.6") x Depth 292mm (11.5")

Note- The heights quoted excludes the supplied floor spikes and Domed Gel Pads (add 15mm to allow for this on all height options). **Moseco CC speaker stands are supplied as singles. Bamboo is a natural material so the underlying colour, texture, grain and age will make each speaker stand unique.**

Centre Channel Speaker Stand

Ensign CC Series

Available Colour Finishes

Satin Black (Standard)



Diamond White (Cost Option)



Ensign CC01-500

Ensign CC Series Height Options

- 200- 225mm (8.85") Height
- 300- 325mm (12.8") Height
- 400- 425mm (16.7") Height
- 500- 525mm (20.7") Height
- 600- 625mm (24.6") Height
- 700- 725mm (28.5) Height

Weight capacity 25kg (55lbs)



Ensign CC02-200



Ensign CC02-700

Dimensions

Ensign CC01 Top Plate Dimensions Width 400mm (15.7") Depth 180mm (7.1")

Ensign CC02 Top Plate Dimensions Width 475mm (18.7") Depth 210mm (8.3")

Base Plate Dimensions Width 550mm (21.65") Depth 250mm (9.8")

Note- The heights quoted excludes the supplied Isolation Gel Pads (add 5mm to allow for this on all height options). Ensign CC speaker stands are supplied as singles.

Accessories

Atacama Spike Shoes

HD-S and HD-L

All Atacama speaker stands use spikes on the base plates to aid isolation. To protect delicate floor coverings spike shoes are recommended.

Two sizes are available (20mm and 25mm diameter) in either a Satin Black or Nickel finish and are supplied as a pack of 4.

A set of Neoprene pads are also included to act as a barrier between the shoes and the floor if added protection is required.

Atacama HD-S 20mm Spike Shoes
Atacama HD-L 25mm Spike Shoes



Atacama Isolation Gel Pads (pack of 8)



UPDATED! Designed to adhere to speaker stand top plates and are made from a high performance polyurethane elastomer which, as well as being non-slip and non scratch, gives excellent sound and vibration resistance. Now upgraded to the Trapezoidal high load specification.

Available in clear or black.

Dimensions of each gel pad

Base W/D 20mm x 20mm, (0.79" x 0.79")

Top Face W/D 12mm x 12mm (0.47" x 0.47")

Height H 5mm (0.2")

Weight capacity of each gel pad 9kg (19.8 lbs)

(multiply by the number of gel pads to be used on each top plate for overall capacity).



Accessories

Atacama Mass Loading Plates

Designed to fit NeXXus and the Moseco range, the Mass Loading Base Plate pack adds 1.5 kg to each stand increasing the sound dampening and improving the stability of each support.

Mass Loading Plates are made in the UK from Carbon Steel and comes painted in Satin Black.

Supplied as a Pair.



Please note- The shape may vary from the image as the Mass Loading Plate pack is adapted to fit different models of speaker stand.

Atacama Top Plate Spike Pack

Designed to fit Atacama SL and SLX Series speaker stands for when even more isolation than the supplied Gel Pads are required, each pack contains 8 6mm top spikes and fittings along with a hex key to aid adjustment.



Atacama Base Plate Spike Packs

All Atacama speaker stands come with spikes as standard, however should replacements be required they are available in packs of 8 6mm or 8mm diameter sizes and include locking nuts.



Accessories

Atacama Atabites SMD 7.0 HD Speaker Stand Mass Loading Filler



Maximum Atabite capacity
per pair* of speaker stands

Maximum Atabite Capacity *(Per Pair)	ESSENTIAL	CM	HIFI-AUDIO	PRO-STUDIO
NEXXUS 200	5.32kg	N/A	9.37kg	13.43kg
NEXXUS 300	8.18kg	N/A	14.43kg	20.69kg
NEXXUS 400	11.05kg	N/A	19.49kg	27.95kg
NEXXUS 500	13.92kg	17.6kg	24.56kg	35.21kg
NEXXUS 600	16.8kg	21.25kg	29.65kg	42.50kg
NEXXUS 700	19.67kg	24.87kg	34.70kg	49.73kg
NEXXUS 1000	28.28kg	35.75kg	49.89kg	71.51kg

CYCLONE 5	6.8kg
CYCLONE 6	8.4kg
CYCLONE 7	9.84kg

SLX 200	10.64kg
SLX & AUDITION 300	16.36kg
SLX & AUDITION 400	22.10kg
SLX & AUDITION 500	27.84kg
SLX & AUDITION 600	33.6kg
SLX & AUDITION 700	39.34kg
SLX & AUDITION 1000	56.56kg

MOSECO 5	6.8kg
MOSECO 6	8.4kg
MOSECO 7	9.84kg
MOSECO 10	14.14kg

HMS2X 600	85kg
MOSECO XL 500	30.8kg
MOSECO XL 600	44.53kg

ENSIGN/MOSECO CC 200	2.64kg
ENSIGN/MOSECO CC 300	4.09kg
ENSIGN/MOSECO CC 400	5.5kg
ENSIGN/MOSECO CC 500	6.8kg
ENSIGN/MOSECO CC 600	8.4kg
ENSIGN CC700	9.84kg

*ENSIGN/MOSECO CC SERIES RATED AS A SINGLE STAND



How much do you need?

To get the best possible performance from your speaker stands, it is recommended that the main vertical columns are partially filled with a high density inert filler.

By adding Atabites, you will reduce stand ringing and give a tune-able platform from which to set up your bookshelf speakers.

The amount of filler to use will depend on the speakers, cables, speaker positioning, hifi component match, room acoustics and what sonic characteristics the listener is looking for.

The more Atabites used, the more depth of bass, detail and defined sound stage should be heard.

However, overfilling can dull the stands causing detail and mid-range to soften, so experiment with the amount used to match the speaker stands to your specific requirements.

As a general rule, half to two thirds full gives the best results.

Featuring new zinc coated steel micro-discs, the Atabite SMD-Z 7HD inert filler has a range of particulate sizes giving consistent sonic performance. The Zinc coating adds mass, protects the filler from both oxidization and degradation while enhancing the visual aesthetics.

PLEASE NOTE- Atabites are supplied by weight, not volume. (7 kg tubs). Some settling of contents may occur in transit.

As a guide, each 1.8L tub contains approximately 1.6L of Atabites. As a comparison, 1.6L of typical dry *beach sand would weigh less than 2.5kg.

Source:

<https://www.traditionaloven.com/building/beach-sand/convert-beach-sand-liter-to-kg-of-beach-sand.html>

Comparison Chart & Technical Specifications

SPEAKER STAND SERIES	STANDARD OR OPTION	TOP PLATE WIDTH	TOP PLATE DEPTH	BASE PLATE WIDTH	BASE PLATE DEPTH	WEIGHT CAPACITY (PER STAND)	HEIGHT OPTIONS EXCLUDING SPIKES AND GEL PADS (UNLESS STATED OTHERWISE)
APOLLO CYCLONE SERIES							
CYCLONE SET UP 1	STANDARD	150mm (5.9")	200mm (7.9")	240mm (9.4")	300mm (11.8")	*7.5KG (16.5lbs)	515mm (20.3"), 615mm (24.2"), 715mm (28.1")
CYCLONE SET UP 2	STANDARD	200mm (7.9")	150mm (5.9")	240mm (9.4")	300mm (11.8")	*7.5KG (16.5lbs)	
NEXXUS SERIES							
NEXXUS ESSENTIAL SPEC	STANDARD	130mm (5.2")	170mm (6.7")	260mm (10.2")	365mm (14.37")	15KG (33.06 lbs)	ALL NEXXUS VERSIONS EXCLUDING CM
NEXXUS HIIFI-AUDIO SPEC	STANDARD	130mm (5.2")	170mm (6.7")	260mm (10.2")	365mm (14.37")	22.5KG (49.06 lbs)	INCLUDING FLOOR SPIKES, 220mm (8.66"), 320mm (12.59"), 420mm (16.53")
NEXXUS CM SPEC	STANDARD	130mm (5.2")	170mm (6.7")	260mm (10.2")	365mm (14.37")	22.5KG (49.06 lbs)	520mm (20.47"), 620mm (24.4"), 720mm (28.34"), 1020mm (40.15")
NEXXUS PRO-STUDIO SPEC	STANDARD	130mm (5.2")	170mm (6.7")	260mm (10.2")	365mm (14.37")	30KG (66.12 lbs)	CM Spec 520mm (20.47"), 620mm (24.4"), 720mm (28.34"), 1020mm (40.15")
TOP PLATE PACK	OPTIONAL	160mm (6.3")	220mm (8.7")				
TOP PLATE PACK	OPTIONAL	140mm (5.5")	210mm (8.3")				
TOP PLATE PACK	OPTIONAL	180mm (7.1")	150mm (5.9")				
TOP PLATE PACK	OPTIONAL	190mm (7.5")	305mm (12")				
MOSECO SERIES							
MOSECO SET UP 1	STANDARD	130mm (5.2")	170mm (6.7")	240mm (9.4")	280mm (11.1")	*7.5KG (16.5lbs)	515mm (20.3"), 615mm (24.2"), 715mm (28.1"), 1015mm (40")
MOSECO SET UP 2	OPTIONAL	160mm (6.3")	220mm (8.7")				
TOP PLATE PACK	OPTIONAL	140mm (5.5")	210mm (8.3")				
TOP PLATE PACK	OPTIONAL	180mm (7.1")	150mm (5.9")				
SIXX SERIES							
SIXX SET UP 1	STANDARD	225mm (8.9")	225mm (8.9")	305mm (12")	305mm (12")	15KG (33lbs)	INCLUDING FLOOR SPIKES & GEL PADS-235mm (9.25"), 335mm (13.19"), 435mm (17.12"), 535mm (21.06"), 635mm (25"), 735mm (28.9"), 1035mm (40.75")
HMSX2 SET UP 1	STANDARD	200mm (7.9")	225mm (8.9")	305mm (12")	305mm (12")	42KG (92.6lbs)	607mm (23.9")
HMSX2 SET UP 2	STANDARD	225mm (8.9")	200mm (7.8")	305mm (12")	305mm (12")	42KG (92.6lbs)	607mm (23.9")
MOSECO XL SERIES							
MOSECO CC SERIES							
CC01	STANDARD	400mm (15.7")	180mm (7.1")	600mm (23.6")	292mm (11.5")	25KG (55lbs)	
CC02	STANDARD	475mm (18.7")	210mm (8.3")	600mm (23.6")	292mm (11.5")	25KG (55lbs)	215mm (8.5"), 315mm (12.4"), 415mm (16.3"), 515mm (20.3"), 615mm (24.2")
CC03	STANDARD	550mm (21.7")	250mm (9.8")	600mm (23.6")	292mm (11.5")	25KG (55lbs)	
ENSIGN SERIES							
ENSIGN CC01	STANDARD	400mm (15.7")	180mm (7.1")	550mm (21.7")	250mm (9.8")	25KG (55lbs)	INCLUDING FLOOR SPIKES-225mm (8.85"), 325mm (12.8"), 425mm (16.7"), 525mm (20.7"), 625mm (24.6"), 725mm (28.5")
ENSIGN CC02	STANDARD	475mm (18.7")	210mm (8.3")	550mm (21.7")	250mm (9.8")	25KG (55lbs)	
AUDITION SERIES							
AUDITION SET UP 1	STANDARD	360mm (14.2")	225mm (8.9")	400mm (15.7")	305mm (12")	20KG (44lbs)	INCLUDING FLOOR SPIKES & GEL PADS- 335mm (13.19"), 435mm (17.12"), 535mm (21.06"), 635mm (25"), 735mm (28.9")
AUDITION SET UP 2	STANDARD	225mm (8.9")	360mm (14.2")	305mm (12")	400mm (15.7")	20KG (44lbs)	

*** CYCLONE AND MOSECO WEIGHT CAPACITIES CAN BE INCREASED 25% IF MAIN COLUMN IS 1/2 OR MORE MASS FILLED WITH ATABITES.**

COLOUR OPTIONS	STANDARD SATIN BLACK	STANDARD SILK BLACK	COST OPTION DIAMOND WHITE	COST OPTION GLASS/SATIN BLACK*	NATURAL FINISHES ARE STANDARD, ALL OTHERS ARE COST OPTION WOOD BASE PLATE COLOUR CHOICE
APOLLO CYCLONE SERIES	NO	YES	NO	NO	NATURAL OAK FINISH, DARK OAK FINISH
NEXXUS SERIES	YES	NO	YES	NO	N/A
MOSECO SERIES	YES	NO	YES	NO	NATURAL BAMBOO FINISH, DARK FINISH
SLX SERIES	YES	NO	YES	NO	N/A
HMS SERIES*	YES	NO	*SPECIAL COMMISSION	NO	N/A
MOSECO XL SERIES	YES	NO	YES	NO	NATURAL BAMBOO FINISH, DARK FINISH
MOSECO CC SERIES	YES	NO	YES	NO	NATURAL BAMBOO FINISH, DARK FINISH
ENSIGN SERIES	YES	NO	YES	NO	N/A
AUDITION SERIES	YES	NO	YES	NO	N/A

ALL SERIES ARE SUPPLIED IN PAIRS WITH THE EXCEPTION OF ENSIGN AND MOSECO CC.

CABLE MANAGEMENT TWIN 50.8MM (2") TUBE PACKS - AVAILABLE SUMMER 2022- TO FIT ALL STANDARD SPEAKER STANDS WITH HEIGHT OPTIONS ABOVE 500mm (EXCLUDING MOSECO & PRO-STUDIO)
NOTE- BY FITTING THE CABLE MANAGEMENT TUBE PACK, THE OVERALL MASS LOADING FILLER CAPACITY FOR THE SPEAKER STANDS WILL BE REDUCED DUE TO THE NEW TUBES NEEDING TO REPLACE TWO EXISTING VERTICAL TUBES.

GLOSS/SATIN BLACK* COLOUR OPTION- ONLY THE 50.8mm (2") TUBES ARE PAINTED GLOSS BLACK- ALL OTHER MAIN COMPONENTS ARE SATIN BLACK.

Atacama

Need assistance selecting the right speaker stands? Contact your local Atacama stockist with the following information and they will be happy to help!

Make and model of speakers

Width of speaker cabinet

Depth of speaker cabinet

Approximate weight of speaker

The height you would like the speakers to stand

**Approximate size of room
(To help estimate Atacama requirement)**

**Floor covering
(Spike shoes may be required)**

Atacama Audio
Sambell Engineering Ltd
Winston Avenue
Croft
Leicester
Leicestershire
United Kingdom
LE9 3GQ

Tel: 01455 283251
Fax: 01455 283908

www.atacama-audio.co.uk
post@atacama-audio.co.uk



**Atacama
2 YEAR
GUARANTEE**

We offer a full 2 years guarantee against manufacturing defects on all Atacama products giving you peace of mind and assurance of quality.

We operate a policy of continuous improvement and reserve the right to amend designs and specifications without prior notice. All dimensions in this brochure are approximate only.